

**RERODE**

**THE  
R1+**

**FOLLOW YOUR HEART  
AND TO BE THE  
TRULY SELF**



*RERODE R1+ Off-road  
Motorcycle User Manual*

The off-road motorcycle is intended for use in restricted areas only.

Please read the user manual carefully before using this product. Do not use this product until you have a clear understanding of its features. Please keep the manual in a convenient place for future reference.



## PACKING LIST

Please carefully check whether all items in the package are complete and intact or not, If there are any problems such as damages or missing, you can contact the dealer or the manufacturer for assistance.

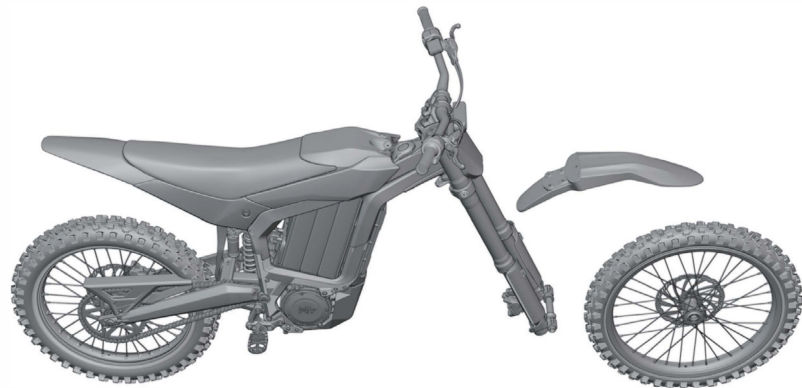

User Manual & After-sales Manual



Packing List & Quick Assembly Guide



Display Manual

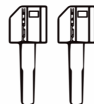

key\*2



Charger storage bag



Front Fender

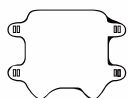

Number Plate



Toolkit



Foot Peg

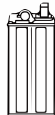

Battery

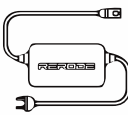

Charger



Rubber Zip Tie \*2

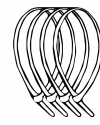

8\*200mm Zip Tie\*2

## QUICK ASSEMBLY GUIDE

### Handlebar Assembly

1.Loosing the 4 locking Screws with 5mm internal hexagonal wrench and taking the fixing cover down.

*Keep the handlebar and thottle loose*

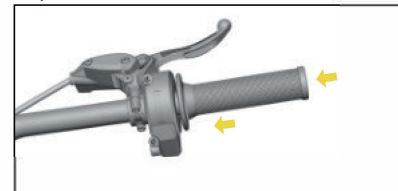

3.Press the handlebar against the front headlight bracket, align it with the mounting hole, and tighten the screws

*\*Tighten the screws in a diagonal patterns.\**

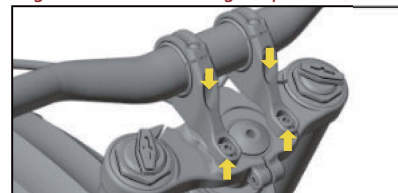

2.Loosing the 4 headlight bracket Screws with 5mm internal hexagonal wrench and taking them down

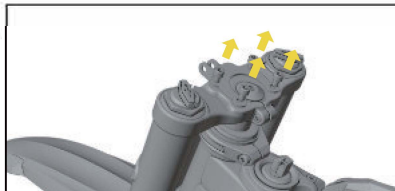

### Headlight Assembly

1.Fix the headlight to the mounting bracket of the connecting plate on the front fork.

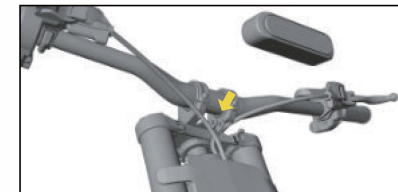

2.Adjust the position and tighten the screws on the both sides.



## Front Brake Lever/Throttle Assembly.

1. Please adjust the front brake lever and throttle to the end, then back off 2mm

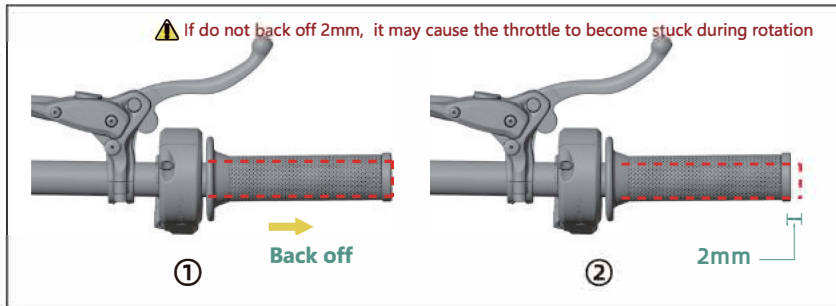

2. As shown in the illustration, the gap between the brake lever and throttle is no less than 12mm (it can be adjust according to personal habits).

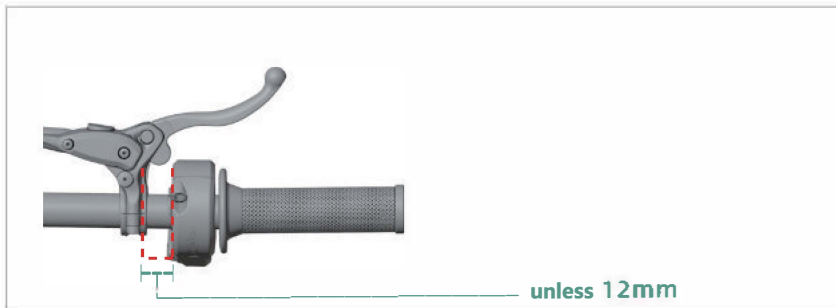

3. Tilt the front brake lever forward at 35°, to avoid the interference of the front brake lever and throttle, the front brake should be perpendicular to the vertical plane of front side of throttle.

3

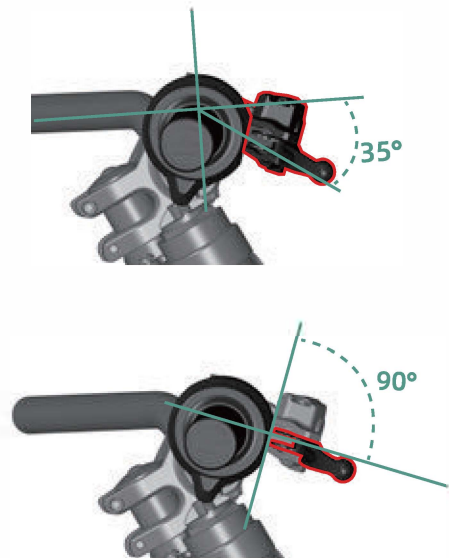

4. Tighten the throttle and brake lever with 4mm hexagonal wrench, then rotate the throttle and check whether the throttle can smoothly return (you can check the mount position of the throttle and the direction of the throttle cable, if it is jammed)

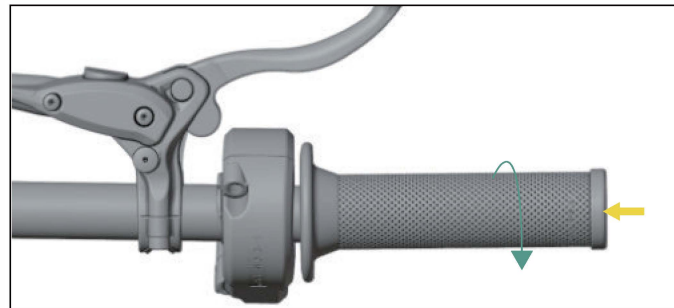

## Throttle Cable Assembly

1. As shown in the illustration, fix the throttle cable, the left combination switch and the speedometer cable on the handlebar respectively, and cut the extra tie.

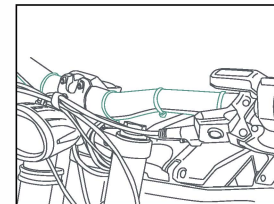
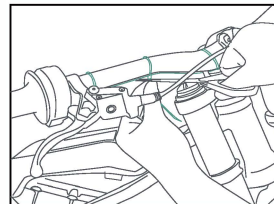
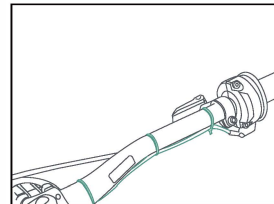
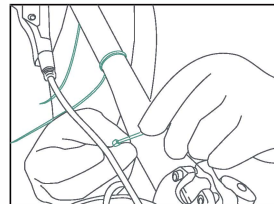

2. Organize the cables to make sure there is no bending around the tube.

Note 1: Fix the brake hose and combination switch cable with rubber tie respectively

\*Note: there is no need in tying up the brake hose and brake signal line.

Note 2: Rotate the handlebar to make sure all cables are loose, and no tension and strain

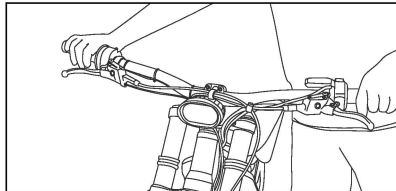
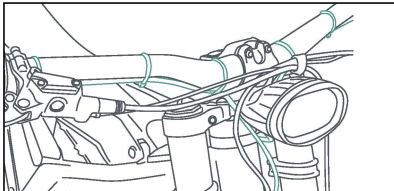

**!** Note 3: Please avoid intertwining the relevant cables before assembling the headlight, front brake lever and throttle

## Front Wheel Assembly

1. Loosening the 4 locking bolts below the front shock absorption with 4mm inner hexagonal wrench.

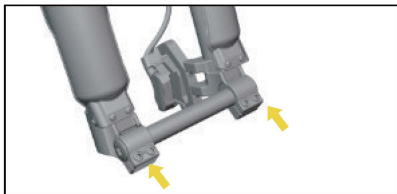

3. Please separately mount the front wheel bushing on either side of the front wheel axle, make sure the bushing is properly installed and all the seals are well placed, the bushing can move freely.

Do not damage the sealing ring

5

2. Loosening the locking nuts located on either side of the front wheel axle with 8mm inner hexagonal wrench, and slightly knock the axle to take it out.



4. Remove the brake clipper clamping block, and place the front wheel on the wheel mounting position of front shock absorption.

Please pay attention to the brake clipper as you mount the front wheel



6. Tighten the locking nuts on either side with 8 mm inner hexagonal wrench.

Pre-tightened 4 locking nuts in case of slipping



## Number Plate Installation

1. As shown in the diagram, fasten up 2 200 mm cable ties onto the number plate. Remove the screws from the bottom of the number plate and keep them for later use.

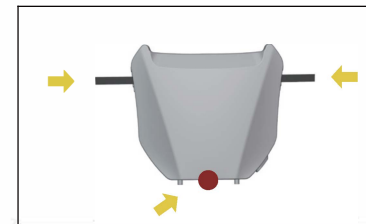

2. Fix the number plate onto the front fork

\*Hiding the cable ties behind, the number plate.

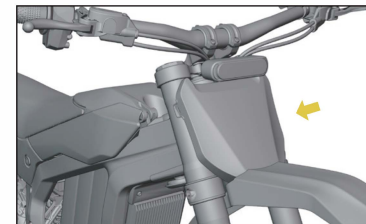

5. Mounting the axle, and making it through the front wheel axle and the shock absorption in turn.

The front brake should not be used until front wheel is installed



7. Tighten the 4 locking bolts below the front shock absorption with 4mm inner hexagonal wrench in a torque of 6 to 8 N.m



3. Use the screw in the first step to fix the number plate on the front fender, and secure it to the front fork with cable ties

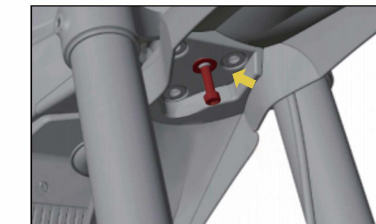

## Front Fender Installation

1. Removing the 4 bolts and The T shaped gasket.

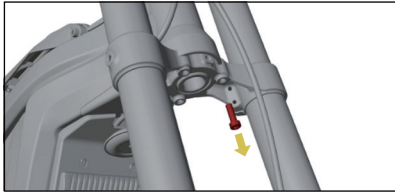

2. Mounting the T shaped gasket onto the 4 bolts. Make sure the direction of the T shaped gasket as the diagram.

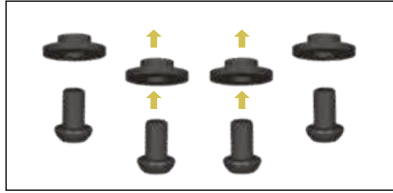

3. Mounting the Front fender with 4mm inner hexagonal wrench with a torque 5N.M, and make sure the front fender is tightly fixed.

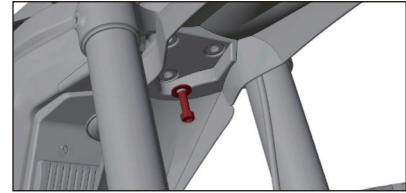

## Foot Peg Assembly

1. Removing the screws of the foot peg.



2. Insert the foot peg to the hole of the support plate.



3. Tighten the screws with 18mm open-ended wrench.

