

**RERODE**

**THE  
R1**



***Rerode R1 Off-road Motorcycle  
User Manual&After-sales Manual***

THE ELECTRIC OFF-ROAD MOTORCYCLE IS INTENDED  
FOR USE IN RESTRICTED AREAS ONLY.

Please read the user manual carefully before using this product. Do not  
use this product until you have a clear understanding of its features.  
Please keep the manual in a convenient place for future reference.



**WARNING**

*When riding, please wear a safety helmet and obey the local traffic law and regulations.*

*Do not ride when the battery compartment cap is not fully secure.*

*Do not ride bike into the water, otherwise it will damage the battery and motor, and even cause personal injury.*

*Please take out the battery before washing the bike. Do not apply the high-pressure washer direct on the battery or other electrical parts.*

**TO:**

THANK YOU FOR CHOOSING THE RERODE PRODUCTS.  
YOUR SUPPORT AND TRUST IN RERODE ARE MUCH APPRECIATED  
LET'S EMBARK ON AN EPIC MOTORCYCLE JOURNEY.

**SCAN THE QR CODE ABOVE TO GET THE USER MANUAL AND REPAIR MANUAL**

**Welcome** ..... 1  
**VIN Number** ..... 1  
**Label Position** ..... 2  
**Safety Instructions** ..... 3  
 Requirements for Riding Conditions..... 4  
 Pre-ride Inspection ..... 4  
 Riding Instructions ..... 5  
 Usage Instructions ..... 5  
**Function Diagram** ..... 6  
**Instrument menu page & fault codes** ..... 7  
**Quick Installation Guider** ..... 10  
 Headlight Installation ..... 10  
 Handlebar Installation ..... 10  
 Front Brake Lever/Throttle Installation..... 11  
 Throttle Cable Installation..... 12  
 Front Fender Installation ..... 13  
 Front Wheel Installation ..... 13  
 Number Plate Installation..... 15  
 Foot Peg Installation ..... 15  
**How to Ride** ..... 16  
 Starting and Operating..... 16  
 Braking ..... 16  
 Battery Installation ..... 17  
 Parking ..... 18

**Well Prepared Before Riding** ..... 18  
 Check Tires ..... 18  
 Check Instrument,Horn,and Brakes ..... 18  
 Check Handlebars ..... 18  
 Shock Absorption Adjustment ..... 18  
**General Operation** ..... 19  
**How to Charge** ..... 20  
 Charging ..... 20  
 Portable Charger ..... 20  
 Precautions for charging ..... 21  
**Specifications** ..... 22  
**Other Statements** ..... 23  
 Circuit Diagram ..... 24  
**Troubleshooting and Remedies** ..... 25  
**Maintenance Guidance** ..... 27  
 Check parts ..... 27  
 Check Operational Unit ..... 28  
 Check the Battery ..... 29  
 Charging and Charger Usage ..... 29  
 Motor and Controller Usage and Maintenance ..... 29  
 Replace Fuse ..... 30  
**Condition of Warranty** ..... 30  
**Packing List** ..... 31



## WELCOME:

Thank you for choosing the RERODE R1 electric off-road motorcycle.  
This product complies with the quality standards of EGIMOTORS S.R.L.

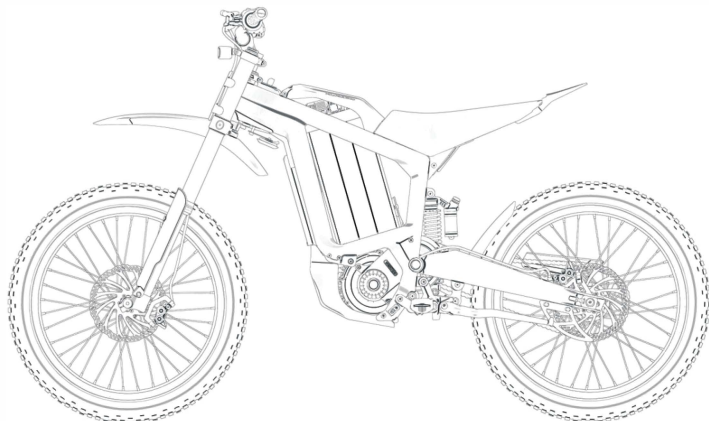

For your safety, please read this manual carefully before riding the bike. Please keep this manual properly. Do not ride until you fully understand this bike. Do not use the bike until you are familiar with its performance, operation, and maintenance. All pictures in this manual are for reference only. This manual contains the word WARNING to indicate something that could hurt you or others. It also contains the word CAUTION to indicate things that could damage your bike.

## VIN NUMBER



## LABEL POSITION

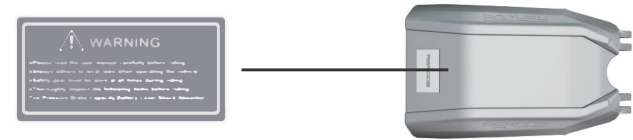

Riding Warning Label Location

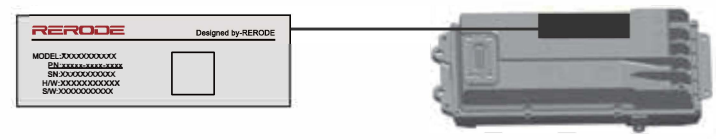

Controller Label Location

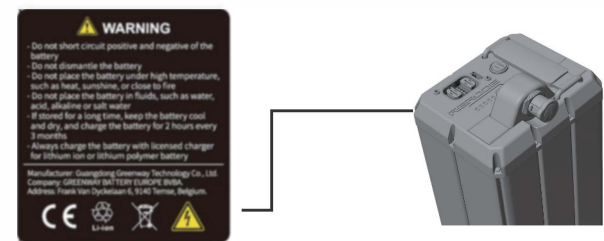

Battery Warning Label Location

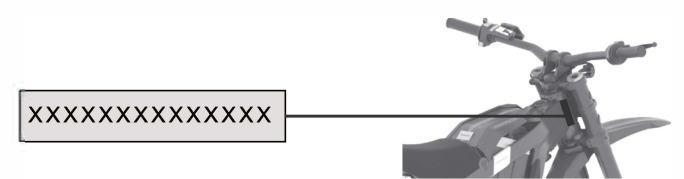

VIN Number Location

## SAFETY INSTRUCTIONS

- Check the local laws and regulations, it is prohibited to ride in public road and bike lanes.
- You are obligated to know the laws in your area and to comply with related laws and traffic rules.
- User under 18 years old is not allowed to use this product.
- Before using this product, you must have motorcycle riding license and are recommended to have the necessary proper motorcycle riding skills after professional training.
- Read all additional warnings and product instructions in this Owner's Manual, as well as safety labels, before operating your electric motorcycle. Please find an open and safe place to practice in order to fully understand the bike and get the basic riding skills of the bike and know its structure, which is the premise of safe riding.
- Never permit a guest to ride your electric motorcycle without proper instruction. Do not lend this bike to people who are unfamiliar with it, so as to avoid injury, please make sure that the rider (you or others) has

- read the instructions and watched the instructional video before riding alone. Persons unwilling or unable to take responsibility for their actions should not use this motorcycle. You assume all responsibility while operating your bike.
- Proper safety gear, including a regionally approved helmet, goggles, riding boots, gloves, and protections should be worn while riding to reduce the risk of potential injury.
- Do not park inside the building, evacuation staircases, walkways and emergency exits.
- Do not charge or park in residential buildings. Charging should be kept away from combustibles and never over charging.
- This product is ridden by one person only, please do not take any passenger or carrying other items.
- When riding, please wear loose, cuff-tightened clothes in bright colors, which are supposed to ensure your safety. Do not wear slippers or high heels when riding.
- This product contains many electrical parts, so please do not leave it in the rain for too long.
- Precautions for bike washing: please remove

the battery before washing. It is prohibited to use high-pressure washer to directly wash the battery or other electrical parts.

- Do not immerse the battery in water. (With damaged appearance, the waterproof performance of the battery will be damaged.) The wading depth cannot exceed the center of the wheel, otherwise it may damage the battery and cause severe injury. It is forbidden to charge the battery under the circumstances above, otherwise it will cause fire, burning or even explosion.
- For your safety, please do not modify this product without the manufacturer's permission. Rerode will not take liability for non-approved modifications. If your parts on the bike need to be replaced, please contact your local authorized dealer.
- If alarm or warning code is triggered, please stop using the bike immediately.

## REQUIREMENTS FOR RIDING CONDITIONS

- Do not ride in extreme weather or if the rider is not in good health condition. When riding in the rain or in the snow, braking distance will be extended, so please avoid riding in heavy rain and other extreme weather conditions.
- Ride slowly and be careful under the complicated road conditions. When riding this bike at high speed over obstacles including uneven, wet, loose ground, steep slope or sharp bend, you may lose control of riding resulting in collision, fall or injury.
- Please avoid riding in heavy rain or ponding area. When the depth of the water on the road exceeds the wheel center, it may affect the function of the motor and the brake. This bike may be used in the rain and snow, but not for longtime deep wading. The recommended wading depth is within 20cm.
- The working temperature of this product is -10~45°C and storage temperature is -10~45°C. The recommended storage temperature is 10°C to 30°C. Please store or ride under the temperature

within the range above.

Requirements For Riders: (the following persons shall not ride the product)

- Persons under the age of 18.
- Pregnant women or persons unable to engage in vigorous physical activity due to illness.
- Persons under the influence of alcohol or drugs.
- Personnel exceeding the specified weight limit (refer to page 22, "Model Specifications Table").

## PRE-RIDING INSPECTION

- Check if tires have no cracks, no abnormal abrasion, no nails, stones, glass and other foreign bodies embedded in.
- Tire pressure of 2 Bar is required for normal riding.
- Check if axle screws are tightened.
- Check if the handlebars and the front and rear wheels are fixed: to ensure that the handlebars are fixed, the front and rear wheels are stable without shaking, and can work normally.
- Check if the reflector is broken or contaminated.
- Check the status of power circuit and

- lighting circuit to ensure operate normally.
- Check if the front and rear brake system can work normally.
- Make sure the battery capacity meets the riding requirements.
- Check the torque of spokes: tighten it immediately if loose (1.5N·m-2.5N·m).
- Check if the throttle is smooth without stuck and if it can return to idle position normally.
- Check the chain condition: the chain has its floating space under normal conditions. If it gets stuck, please clean and lubricate the chain.

- Check the belt condition: Belt silencer can be used to eliminate the abnormal sound. Please clean the belt if there are any obstacles.
- Check if the inner tube of the front fork is clean.
- Check the back shock absorption inner tube is clean.
- Check if the front and rear brakes can brake normally and ensure there is no damage to the brake cable.

## RIDING INSTRUCTIONS

- When riding, do not use mobile phone, camera, earphones, earplugs, etc, to avoid distraction.
- When you are eager to experience the Rerode R1 electric off-road motorcycle, it is recommended that you ride in a closed and secure area while wearing the appropriate protective gear. Remember not to ride it in public places or on motor vehicle lanes.

- During normal riding, do not use sudden acceleration and hard brake in order to save battery power, protect parts on the bike, improve range and bike's service life.
- If any abnormality occurs while riding, please stop riding immediately. Do not use this product until the cause of the abnormality is identified and repaired. Please contact your local authorized dealer immediately.

## USAGE INSTRUCTIONS

- Place the product on a flat road and do not forget to turn off the key switch. Otherwise, it could cause the bike slip which would cause injury to you and others. Do not place the bike on a slope or on soft ground to prevent the bike from falling over!
- Please be sure to use the manufacturer's lithium-ion battery charger. The charger input voltage is 110V-220V. Store the product safely before charging. Do not charge the bike if the charger and charging port are damaged. Do not charge or park in the non-parking area.

- Make sure the bike stays away from combustibles when charging and disconnect the power supply after fully charged.
- Do not charge the battery below 0°C (32°F), otherwise the battery cells will be damaged. Please charge the battery when the temperature is appropriate for charging.

## FUNCTION DIAGRAM

Please identify the parts of the bike according to the labels in the picture and familiarize yourself with the bike. After the vehicle is powered on, the "READY" will flash on the instrument panel, the vehicle is in parking mode with the electronic throttle offline. Press the P-gear button next to the electronic throttle to deactivate parking mode.

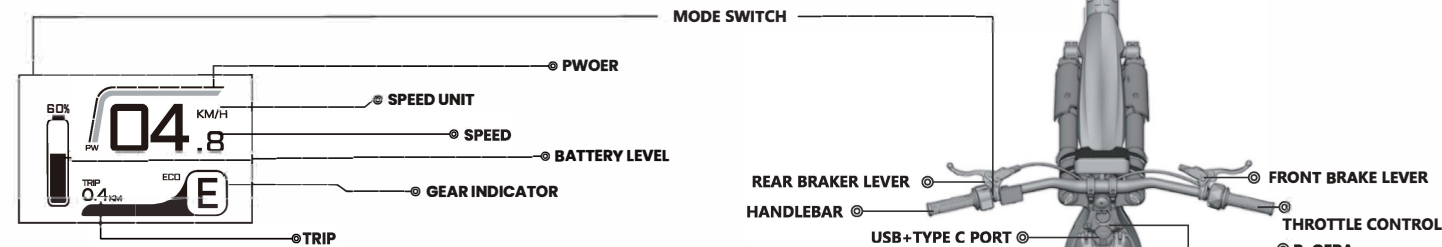

**WARNING** PLEASE READ THE MANUAL CAREFULLY IF YOU ARE A BEGINNER. TO ENSURE THE SAFETY OF INEXPERIENCED RIDERS, THIS INSTRUMENT PANEL INCLUDES A POWER ADJUSTMENT MODE. YOU CAN SET THE POWER MODE THAT SUITS YOUR RIDING EXPERIENCE.

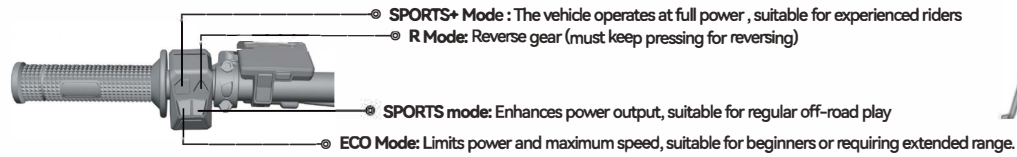

- INSTRUMENT PANEL SETTINGS**
- POWER: PLUS KEY: MINUS KEY:
  - Long press the power button to turn on or off the instrument, and short press the power button to switch between displaying the current mileage, cycling time, average speed, maximum speed, etc.
  - After opening the display, press PLUS KEY and MINUS KEY simultaneously for 3 seconds to enter the settings interface, within 10 seconds.
  - Select the desired setting option by the buttons, use the EXIT option to save and exit.



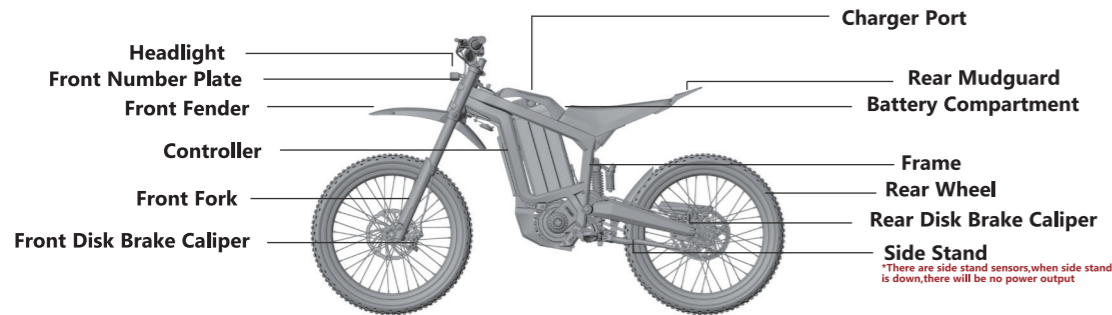

**!** Note: If the temperature of the motor or controller is too high,or the battery power is too low ,the bike will automatically reduce the power to protect the bike.

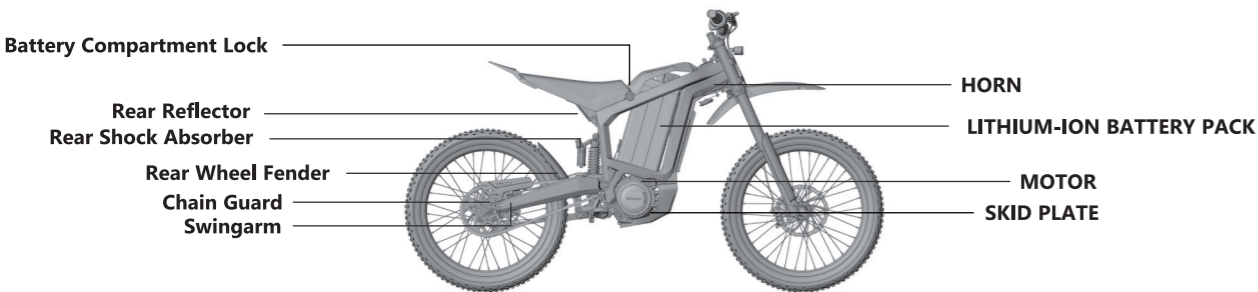

**!** Note: For the purpose of maintenance and service,each bike has its unique VIN number and motor number,please keep these numbers properly.The VIN number is place on the steering tube and the motor serial number is engraved on the body of the motor.

Sub-manual 1 backlight setting (5 is the highest level)

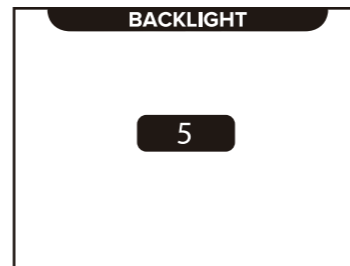

Sub-manual 2 speed-unit settinging (Default KHP)

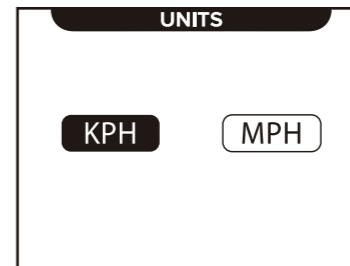

Sub-manual 3 gear ratio settinging

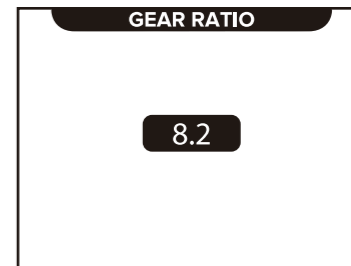

Sub-manual 4 wheel size settinging (Default original back tire size)

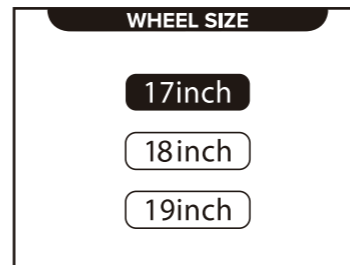

Sub-manual 5 EABS rating settinging

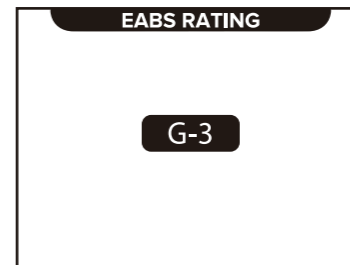

Sub-manual 6 version number



## INSTRUMENT MENU PAGE & FAULT CODES

## Fault Code Display

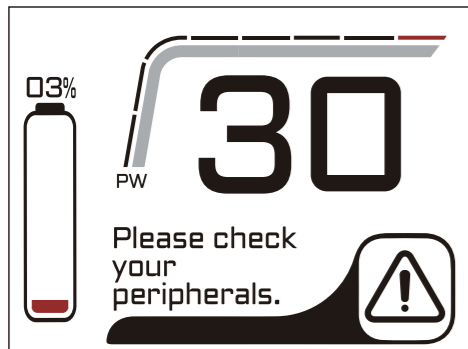

## Fault Code Display:

### Battery

- ERR-01 : Protection IC Error.
- ERR-03 : Voltage of battery cells are not balanced.
- ERR-05 : Storage error.
- ERR-07 : Discharge MOS error.
- ERR-09 : Over charge error.
- ERR-11 : Level 2 over discharge error.
- ERR-13 : Level 2 over discharge current error.
- ERR-15 : Software start failure error.
- ERR-17 : MOS temperature sensor failure error.
- ERR-19 : Battery discharge overheated error.
- ERR-21 : Battery discharge low temperature error.
- ERR-23 : Battery discharge, MOS overheated error.
- ERR-25 : Soft-start circuit overheated error.
- ERR-27 : Discharge fuse failure error.
- ERR-29 : Level 3 over current error.
- ERR-31 : Setting error.

- ERR-02 : Battery cell connection wire disconnected.
- ERR-04 : Battery capacity measurement error.
- ERR-06 : Time display error.
- ERR-08 : Charge MOS error.
- ERR-10 : Level 1 over discharge error.
- ERR-12 : Level 1 over discharge current error.
- ERR-14 : Over charge current error.
- ERR-16 : Pre-charge time-out error.
- ERR-18 : Battery cell temperature sensor failure error.
- ERR-20 : Battery charge overheated error.
- ERR-22 : Battery charge low temperature error.
- ERR-24 : Battery charge, MOS overheated error.
- ERR-26 : ROM error.
- ERR-28 : Charge fuse failure error.
- ERR-30 : Level 4 over current error.
- ERR-32 : Reserved.

### Motor

- ERR-33 : Controller phase wire over current error.
- ERR-34 : Controller busbar over current error.
- ERR-35 : Controller MOS error.
- ERR-36 : Tip-over sensor error.
- ERR-37 : Throttle error.
- ERR-38 : Low voltage protection error.
- ERR-39 : Over voltage protection error.
- ERR-40 : Motor hall error.
- ERR-41 : Motor phase wire failure error.
- ERR-42 : Motor overheat error.
- ERR-43 : Motor temperature sensor error.
- ERR-44 : Controller overheat error.
- ERR-45 : Controller overheat error.
- ERR-46 : Current sensor error.
- ERR-47 : Motor lack of phase error.
- ERR-48 : Motor locked-rotor protection error.

## QUICK INSTALLATION GUIDE

### Headlight Assembly

1. Take the screws and gasket off the bracket mounting.

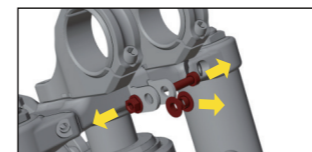

2. Place the gasket into the headlight installation hole.

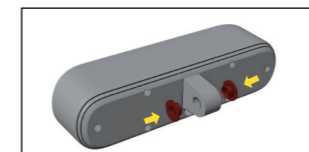

3. Insert the headlight into the bracket mounting position.

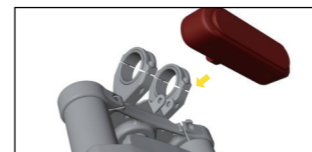

4. Adjust the position and tighten the screws on the both sides with 4mm and 8mm hex wrench.

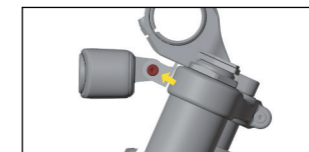

### Handlebar Assembly

1. Tighten and remove the four cap screws of the handlebar clamp with 4MM hex wrench, then remove the handlebar.

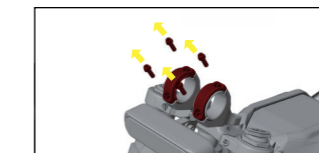

Fix the front brake lever and throttle onto the handlebar in turn.  
*\*Do not tighten them .*

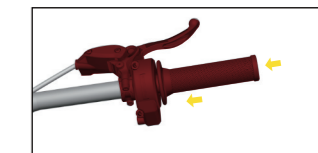

3. Install the handlebar, secure the handlebar clamp, and adjust the position and angle of the handlebar according to personal riding preferences.

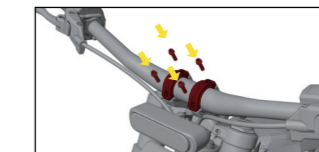

4. Tighten the four bolts to a maximum torque of 6N.M.

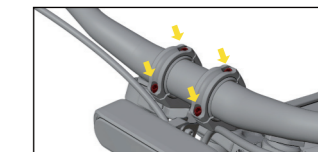

## Front Brake Lever/Throttle Assembly.

1.As shown in the diagram , Please adjust the front brake lever and throttle to the end ,then back off 2mm.

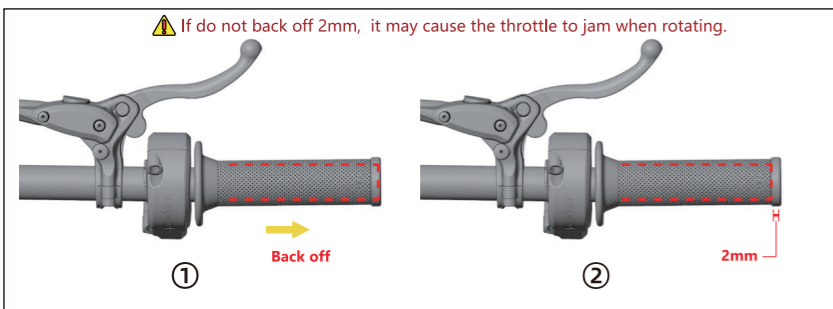

2.As shown in the diagram, the gap between the front brake lever and the throttle grip should not be less than 10mm (adjustable according to personal preference).

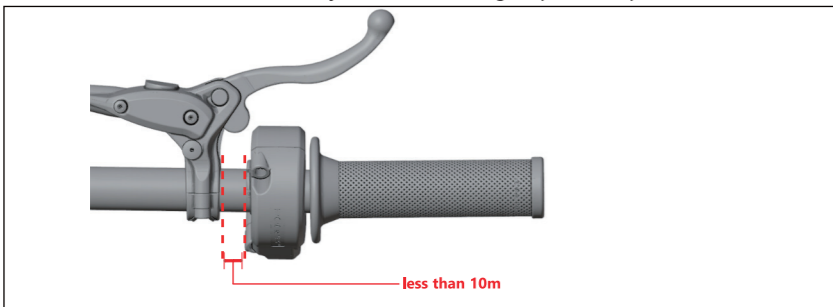

3.It is recommended to install the front brake lever with a forward inclination of approximately 35° (adjustable according to individual usage). Additionally, the front brake lever needs to be perpendicular to the vertical plane in front of the throttle grip to avoid any interference during its use.

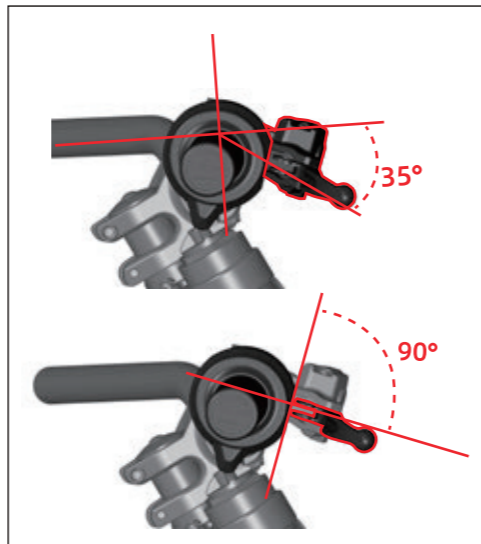

4.Tighten the throttle grip and brake lever with 4mm hex wrench,After screwing the throttle grip all the way, release it to ensure that it returns smoothly and effortlessly.

\*If there is any sticking, check the assembly position of the throttle grip and the direction of the internal cable routing.

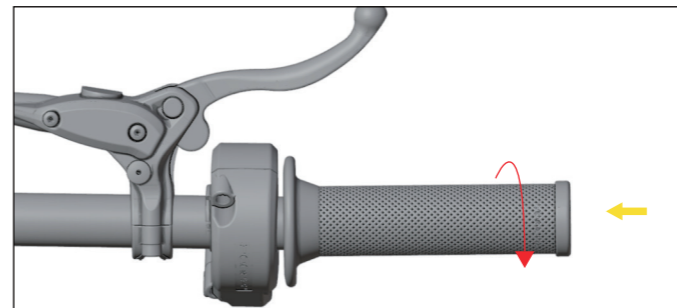

## Throttle Cable Assembly

1.Fix the brake fluid cable and mode switch cable with rubber zip tie.

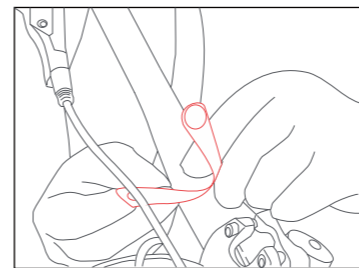

2.Organize the cables to maintain a smooth and uninterrupted path for the fuel line.

\*Do not fix the brake fluid cable and the brake signal wire.

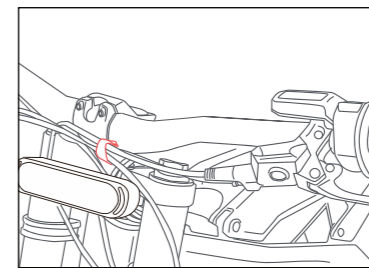

\*After fixing the cables in place, rotate the handlebars to test and ensure that all the cables are relaxed without any pulling or tension.

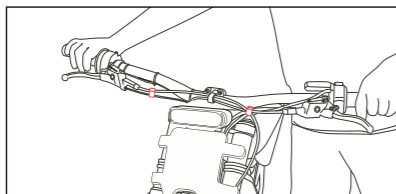
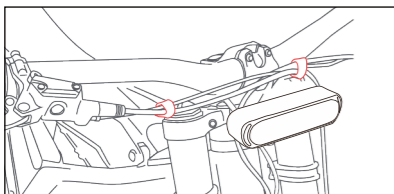

Please do not intertwine or wrap the corresponding cables together when installing the headlight, front brake handle, and throttle handle.

## Front Fender Installation

1. Removing the 4 bolts and The T shaped gasket.

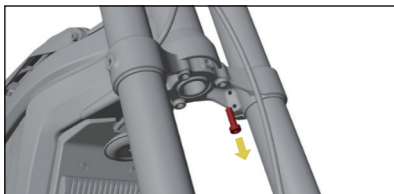

2. Mounting the T shaped gasket onto the 4 bolts. Make sure the direction of the T shaped gasket as the diagram.

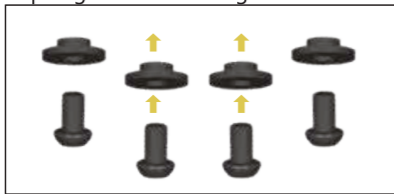

3. Mounting the Front fender with 4mm inner hexagonal wrench with a torque 5N.M, and make sure the front fender is tightly fixed.

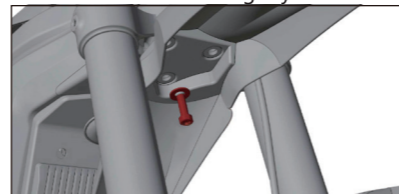

## Front Wheel Installation

1. Loosening the 4 locking bolts below the front shock absorption with 4mm inner hex wrench.

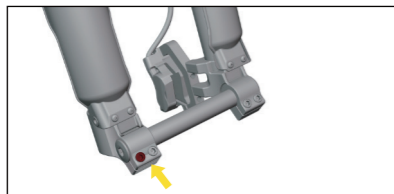

2. Loosening the locking nuts located on either side of the front wheel axle with 8mm inner hex wrench, and slightly knock the axle to take it out.

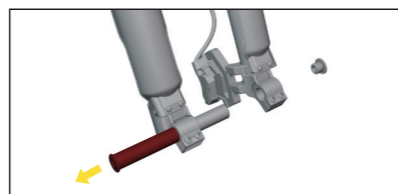

3. Please separately mount the front wheel bushing on either side of the front wheel axle, make sure the bushing is properly installed and all the seals are well placed, the bushing can move freely.

\*Do not damage the sealing ring.



4. Remove the brake clipper clamping block, and place the front wheel on the wheel mounting position of front shock absorption.

\*Pay attention to the compatibility with the disc brake caliper during installation.

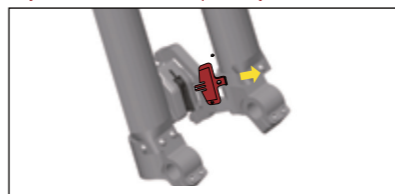

5. Mounting the axle, and making it through the front wheel axle and the shock absorption in turn.

\*The front brake should not be used until front wheel is installed.



6. Tighten the locking nuts on either side with 8 mm inner hex wrench.

\*Pre-tighten 4 locking nuts in case of slipping.



7. Tighten the 4 locking bolts below the front shock absorption with 4mm inner hex wrench in a torque of 6 to 8 N.m.

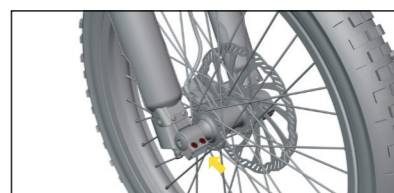

## Number Plate Installation

1.As shown in the diagram,fasten up 4 200 mm cable ties onto the number plate.

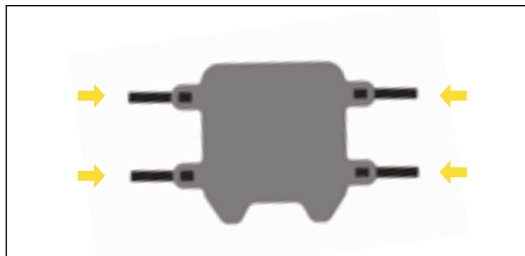

2.Fix the number plate onto the front fork.

\*Hiding the cable ties behind the number plate.

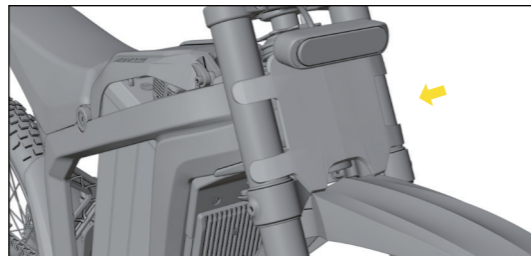

## Foot Peg Installation

1.Removing the screws of the foot peg.

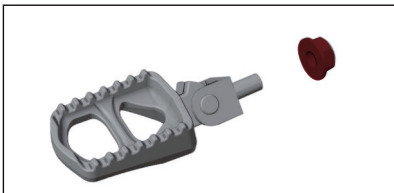

2.Insert the foot peg to the hole of the support plate.

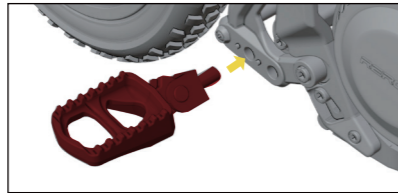

3.Tighten the screws with 18mm open-ended wrench.

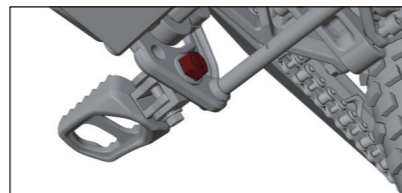

## HOW TO RIDE



WARNING

FOR YOUR SAFETY, PLEASE WEAR FULL-COVER OFF ROAD PROTECTIVE HELMET AND PROTECTIVE GEARS. PLEASE TAKE ALL SAFETY PRECAUTIONS. DO NOT LEND THE BIKE OR ALLOW PERSONS WHO ARE UNFAMILIAR WITH THE BIKE AND UNCAPABLE TO RIDE. IT IS DANGEROUS TO RIDE WITH ONE HAND ONLY OR TWO HANDS OFF THE HANDLEBARS AND RIDE AFTER DRINKING.DO NOT TWIST THE THROTTLE BEFORE SITTING FIRMLY TO PREVENT ACCIDENTS. THE SIDE STAND IS ONLY USED TO SUPPORT THE BIKE. DO NOT LIFT THE SIDE STAND BEFORE SITTING ON THE BIKE.ACCELERATION MUST BE DONE SMOOTHLY AND GENTLY. DO NOT OPERATE VIOLENTLY IN CASE CAUSING DAMAGE TO BIKE PARTS, OR EVEN ACCIDENTS. FOR THE FIRST TIME OF YOUR RIDE, YOU ARE ADVISED TO USE ECO MODE. SPORT MODE CAN BE USED WHEN YOU ARE FULLY FAMILIAR WITH THE BIKE.

## Starting and Operating

1.Insert the key into the key switch and turn on the switch.

2.Check if each switch, instrument,horn,brake, electricity instrument function well.

3.Before starting the motor: fold up the side stand,sit firmly and turn inward slowly to control speed.

4.Speed up and reduce the acceleration by controlling the throttle. Rotate inward to accelerate and outward to decelerate.

\* Before operation, please press the P-GEAR button.

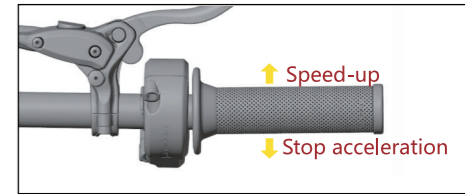
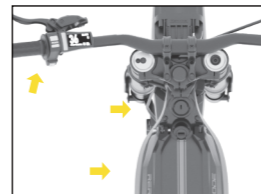
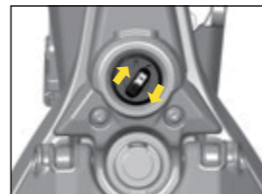

## Braking



WARNING

PLEASE CONTROL THE GRIP STRENGTH OF THE BRAKE LEVER ACCORDING TO THE ACTUAL SITUATION AND GRADUALLY INCREASE THE FORCE. DO NOT EXCESSIVE BRAKING IN CASE THE WHEEL IS LOCKED AND CAUSE SERIOUS DAMAGE. PREJUDGE THE ROAD CONDITION IN ADVANCE CAREFULLY AND AVOID SUDDEN EXCESSIVE BRAKING, STEERING AND OTHER OPERATIONS WHICH MAY CAUSE THE SLIDING AND FALLING, ESPECIALLY IN RAINY DAYS WHEN THE ROAD IS SLIPPERY AND EXTREMELY DANGEROUS.





IT IS NORMAL TO TRIGGER TILT SWITCH OF THE POWER SYSTEM IF BIKE TIP-OVER OCCUR WHEN RIDING (POWER OUTPUT IS CUT OFF, AND IT CAN BE RECOVERED AFTER RIGHTING THE BIKE AGAIN). FOR YOUR SAFETY, PLEASE ENSURE TO TURN OFF THE KEY SWITCH BEFORE LIFTING THE BIKE TO AVOID ACCIDENTALLY TWIST THE THROTTLE AND CAUSE SERIOUS INJURY.

Release the throttle and pull the brake lever to reduce the speed and stop the bike.

•When riding, sudden excessive braking of the right front brake lever may lead to roll over.

•When riding, sudden excessive braking of the left rear brake lever may lead to skid.

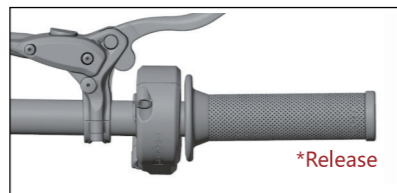

## Battery Installation



TO AVOID DAMAGES OR DANGERS, DO NOT DISASSEMBLE THE BATTERY AND PLEASE MAKE SURE THAT THE KEY SWITCH IS OFF.

1.Open the battery box and take out the battery. Insert the key to the battery compartment lock and rotate counterclockwise to unlock; open the battery compartment cap and check the air circuit switch to make sure it switches OFF.

2.Put the battery into the battery compartment cap.

\*Battery orientation: Charging port faces towards the left side of the vehicle.

3.Connect the main power plug and communication plug.

4.Turn on the air circuit switch, close the battery compartment cap and remove the key.

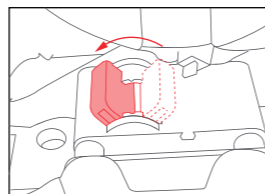
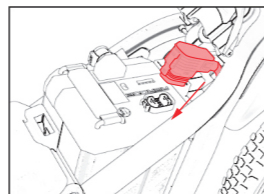
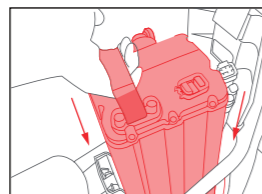
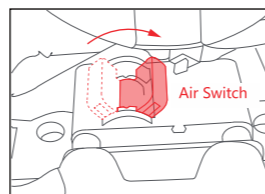
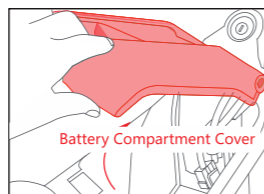
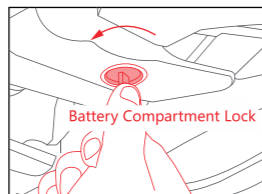

## Parking



PLEASE MAKE SURE TO TURN OFF THE KEY SWITCH WHEN PARKING, TO AVOID ACCIDENTALLY TWIST THE THROTTLE AND CAUSE SERIOUS INJURY. TURN OFF THE KEY SWITCH AND REMOVE THE KEY BEFORE LEAVING THE BIKE.

Pay attention to the road condition, slow down the bike while approaching the parking spot. When the bike stops, turn off the key switch and remove the key. Flip down the side stand to support the bike.

## Caution

- Be cautious and ride slow in complex road conditions.
- It is prohibited to carry people or items on the bike.
- Do not ride when you are tired or in extreme weather.
- Do not ride in the water, otherwise it may damage the battery or even cause personal injury.
- Please hold the handlebars with both hands and do not ride over speed.
- Slow down before turning.
- Do not use mobile phone, camera, earphones, earplugs, etc during riding.

## WELL PREPARED BEFORE RIDING

Please make sure that you have fully read all the details in p04 and check the following items carefully.

### Check Tires

Make sure both tires are in good conditions. Normal tire pressure is 30 psi (207 KPA). Low tire pressure will lead to abnormal wear, poor steering, lower speed, and shorten the range.

Extreme high tire pressure will lead to abnormal wear, poor riding experience, and even tire explosion.

### Check Instrument, Horn, and Brakes

Check if all functions of the instrument are displayed normally.

Check if the horn works properly.

Hold the left and right brake levers respectively to check if the front and rear brakes work normally.

### Check Handlebars

Handlebars need to be fixed tighten and turn freely.

### Shock Absorption Adjustment

Please adjust the front and rear shock absorption according to the actual situations.

The bikes power is cut off (When the power is on but motor not running)

- Side stand switch (with the side stand is down, there will be no power output when turning the throttle)
- Tilt switch (1-2 seconds after the bike falls over, tilt switch will cut the power output)
- Motor overheating
- Battery overheating
- Low Battery capacity
- Controller overheating

### Low Power Mode

- When the battery capacity is less than 15%, the controller will reduce the output to protect the battery, and then the SPORT mode can no longer be used.  
*\*The battery percentage display may be inaccurate because of the battery condition.*
- When the battery level is below 5%, in the case of heavy loads (such as sudden acceleration or uphill driving), the controller may activate under-voltage protection, resulting in the vehicle coming to a stop. If the battery is not promptly recharged, it may enter over-discharge protection at any time (over-discharge protection effectively safeguards the battery cells and requires reactivation with a charger. For detailed reactivation methods, please refer to page 25 "Troubleshooting and Remedies"
- When the controller overheats(exceeding a working temperature of 80°C the vehicle will experience a decrease in power. If the overheating persists and exceeds 100°C, the power output will be cut off).
- When the motor overheats(exceeding a working temperature of 140°C, the vehicle will experience a decrease in power. If the overheating persists and exceeds 150°C, the power output will be cut off).

### Working Conditions

- When the temperature is below 0°C, the battery capacity may correspond to 80% of its normal capacity, and to ride in the SPORT mode is not recommended.
- When the temperature is higher than 40°C, it is recommended not to ride at full power for a long time.

### Riding In The Water

Electrical parts of R1 off-road motorcycle are all designed to have basic waterproofing ability. The wading depth is no more than 20cm, and it cannot be under water for a long time, especially when the motor is in high temperature. When the bike is under water, its internal air will contract, leading to damage while water absorption from the oil seal and cable position into the interior. The followings are the IP level of each component:

- BATTERY, MOTOR: IP65
- CONTROLLER: IP67
- CONNECTOR: IP55

## How to Charge



Do not charge the battery below 0°C, otherwise the battery will be damaged. Wait until the temperature is appropriate to charge. Battery recycling and utilization instructions: damaged or used battery cannot be dismantled without permission and it should be handed over to the manufacturer or designated after-sales service centers for recycling or maintenance. Do not throw away the battery.  
\* When the bike is not used for more than a month, be sure to turn off the air circuit switch or remove the power plug, and store the bike when it is fully charged.  
\* Close the battery compartment cap on the charging port when not charging.



Please make sure to use the manufacturer's lithium-ion battery charger. When replacing the charger, it should match the model of our storage battery. Turn off the air circuit switch before installing or removing the battery from the bike. Disconnect or connect the plug while power cable connected may shorten the battery service life. It is risky to connect the power cable while the air circuit switch is on, it might cause spark and damaged the plug, it may even damage the battery. The charger will be automatically turned off when the battery is fully charged, however, please avoid leaving the charger connected to the power supply for too long.

## Charging

Connect the charger to the charging port and connect the charger to the proper power supply.



After cycling outdoors, it is not recommended to charge the battery right away due to the high temperatures of the battery, electronic controls, and motor. Charging immediately under these conditions may lead to potential malfunctions in the lithium battery. It is advisable to wait for the temperature to decrease before proceeding with the charging process. Battery orientation: Charging port faces towards the left side of the vehicle.

## Portable Charging

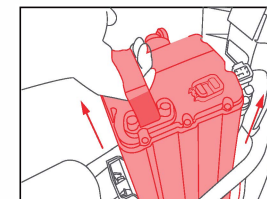
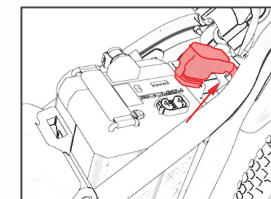
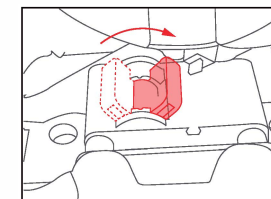
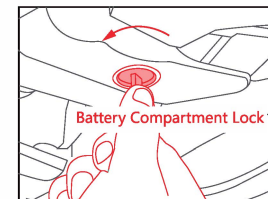

1. Make sure the key switch is OFF. Insert the key to the battery compartment lock, press the battery compartment cap, turn the key counterclockwise, open the battery compartment cap, and turn off the air circuit switch. The foam under the new battery compartment has a large adhesive force with the battery, you may be unable to open. (the battery compartment with just the key. When it happens you need to press the battery compartment cap before opening)

Note: After using the battery for a while, if there is a space between the bottom of the battery and the bottom battery compartment, you may pick up the auxiliary foam pad and stick at the bottom of the battery compartment to keep the battery stable.



2. Pull up and remove the discharge plug and communication plug from the battery vertically.
3. Take out the battery pack and close the battery compartment cap.
4. Connect the charger to the charging port first and then connect to the power supply at the other side.

\*The charger indicator blinking red indicates that the charger is being charging. When the battery is fully charged, the green light is stay on. Remember to cut off power when fully charged. Please turn on the air circuit switch after the battery is connected to the bike.

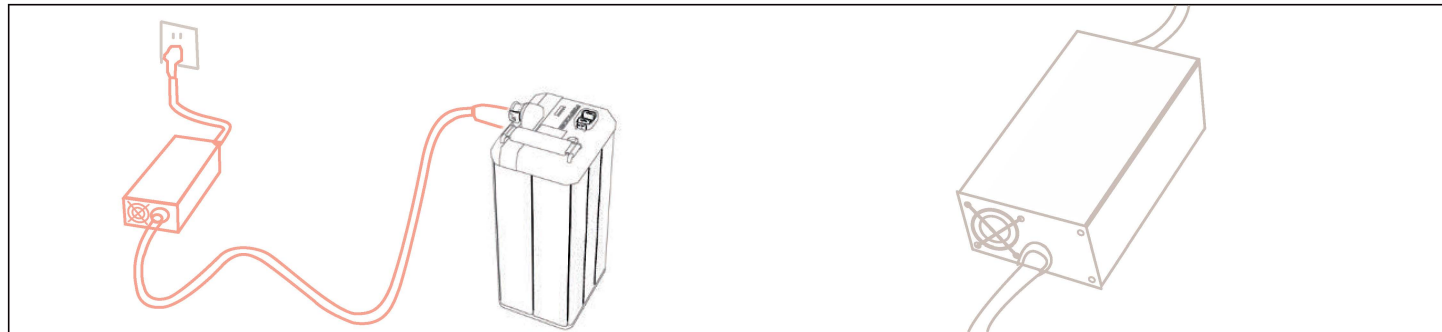

## PRECAUTIONS FOR CHARGING

- When charging, keep the battery in a safe place where children can't reach.
- Do not cover the charger when charging. This charger is for indoor use, please make sure to use it in a dry, well-ventilated environment.
- When you smell something peculiar or find that the temperature of the charger or battery pack is too high, or fully charged indicator never show up after a few hours, please stop charging immediately and send your battery to the local authorized dealer for inspection and maintenance.

## SPECIFICATIONS

ITEM	E-MOTORCYCLE		
<b>BRAND</b>	RERODE R1	<b>PEAK POWER</b>	10KW
<b>SIZE</b>	1870MMX775MMX1100MM	<b>BATTERY TYPE</b>	LITHIUM-ION REMOVABLE BATTERY 35AH/72VH
<b>WHEEL BASE</b>	1240MM	<b>FRAME</b>	ALUMINUM ALLOY
<b>GROUND CLEARANCE</b>	268MM	<b>MOTOR</b>	LPMSM
<b>SHOCK ABSORBER TRAVEL</b>	200MM		FOC SINE WAVE CONTROLLER
<b>SEAT HEIGHT</b>	835MM	<b>CHARGING PORT</b>	USB+TYPE-C DUAL PORT
<b>MAX LOAD</b>	100KG	<b>TIRE</b>	FRONT: 70/100-19 REAR: 70/100-19
<b>WEIGHT</b>	59KG		
<b>MAX MILEAGE</b>	120KM (25KM/H)	<b>RIDING MODE</b>	ECO SPORTS / SPORTS+
<b>PEAK TORQUE</b>	390N·M	<b>FRONT AND REAR BRAKES</b>	203MM HYDRAULIC DISC BRAKE
<b>MAX SPEED</b>	85KM/H	<b>DISPLAY</b>	2" TFT SCREEN, APP
<b>CHARGE TIME</b>	4H	<b>CHARGE TYPE</b>	DC-72V
<b>WATERPROOF RATE</b>	IP65	<b>ASSISTANCE FUNCTIONS</b>	RE-GEN

## OTHER STATEMENTS

1. Manufacturer continuously improves the product quality and performance. Therefore, this manual contains the most latest available product information at the time of printing. Because of this, it is possible that your motorcycle may differ from the information supplied in this Owner's Manual. If there is any difference between the logo or picture in the manual and the actual product, please refer to the actual product.
2. To the extent permitted by law, the Manufacturer reserves rights to interpret and explain this statement.
3. Manufacturer is not liable for all claims, liabilities and losses caused or likely to be resulted from consumers' violation of the terms above. Riders should be responsible for unforeseeable or unavoidable risks while riding.
4. If you want to resell or give away your Rerode R1 off-road motorcycle, please do not forget to pass along this manual as it is part of the product. If you have any questions, please contact EGIMOTORS S.R.L.. Thank you again for your choice and trust in us.

## CIRCUIT DIAGRAM

5. Individuals who are unwilling or unable to take responsibility for their own actions are advised not to use this product. When operating the R1 electric motorcycle, you should hold yourself accountable for your actions. The seller will not be held responsible for misuse or operator negligence.
6. Modifying the R1 electric motorcycle may render the vehicle unsafe and potentially result in serious personal injury. The manufacturer is not responsible for unauthorized modifications.
7. The user is personally responsible for any component damage or riding accidents caused by incorrect maintenance, disassembly, or installation.
8. The three-electric system (Motor, Controller and Battery) is a high-precision and high-risk electrical equipment. There may be certain risks during usage, and the user has fully understood and accepted these risks. In the event of any personal injury caused by such risks, this company does not assume any joint liability.

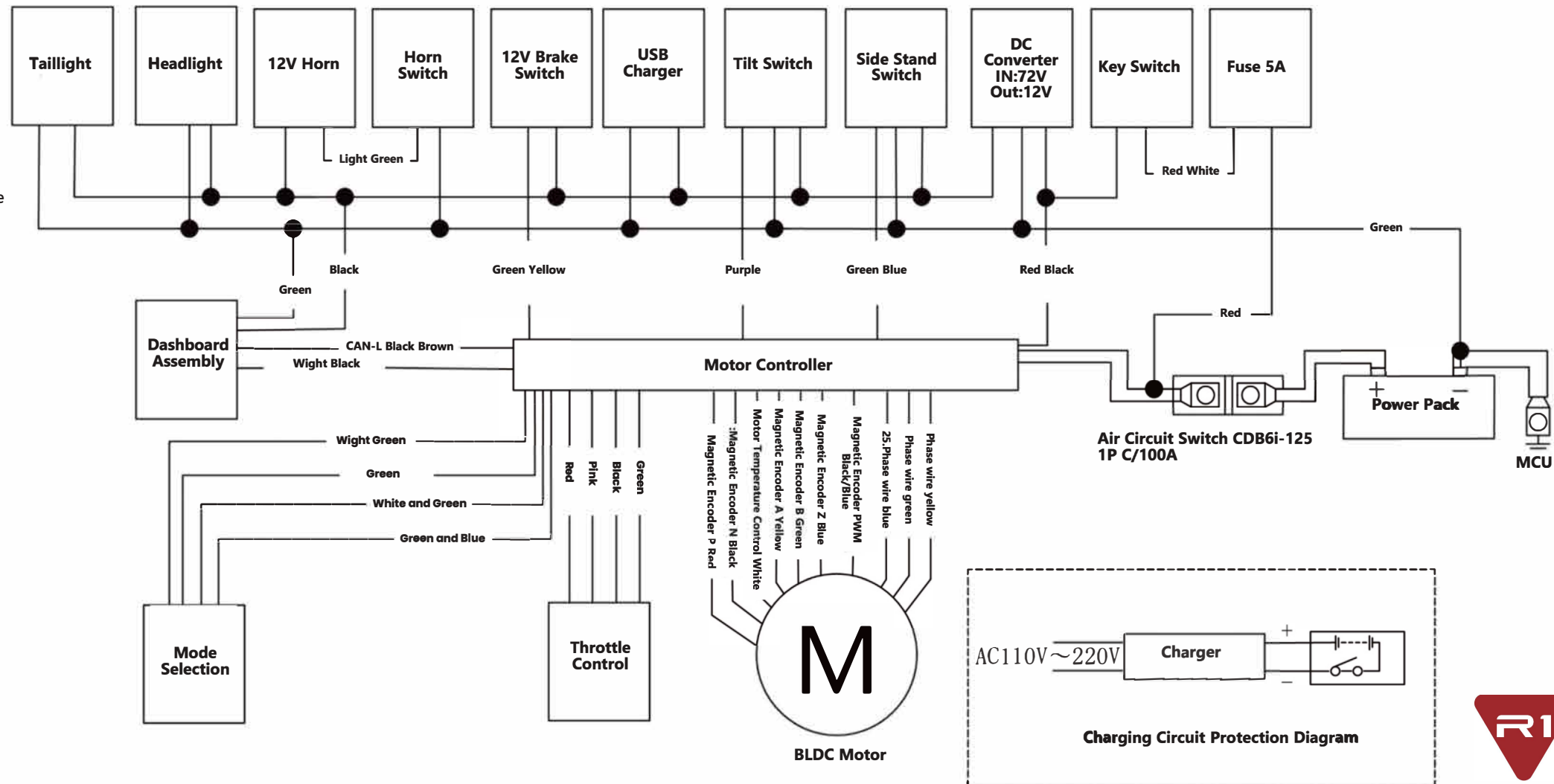

## TROUBLESHOOTING AND REMEDIES

ITEM	FAULT CAUSE	TROUBLESHOOTING METHODS
<b>Power On the vehicle doesn't work</b>	The battery plug is loose or disconnected	check and insert the plug firmly
	Low battery protection activated	Charge the battery
	The battery is in temperature protection	Wait for the bike temperature to return to normal
	The fuse of main cable blow	Check the wire harness and replace the fuse
	The key switch connector is not stable	Insert the key firmly or replace the key switch
	The Converter is damaged	Replace the converter
	The battery is damaged	Please contact the designated after-sales service station for battery repair or replacement.
<b>Power on the motor doesn't work</b>	Side stand switch protection	fold up the side stand
	Brake lever cannot return to idle or malfunctioned	Check the brake lever
	Tilt switch protection activated	Lift up the vehicle ,turn off the key switch and then turn on the key switch
	Power on the throttle handlebar doesn't reset for protection	Adjust the handlebar travel
	Low battery protection	Charge the battery
	Motor temperature Protection	Wait for the motor temperature to return to normal
	Controller temperature protection	Wait for the controller temperature to return to normal
	Side stand switch is damaged ,	Plug off the side stand switch or replace the side stand switch
	Brake cut-off switch is damaged	Plug off the brake cut-off switch or replace the brake cut-off switch
	Tilt switch sensor is damaged	Plug off the tilt switch sensor or replace the tilt switch sensor
	The throttle is malfunction	Replace the Throttle
	The plug of controller is loose or disconnected	Reconnect the plug of the controller
	The plug of motor encoder is loose or disconnected	Reconnect the plug of motor encoder
	The controller or motor encoder malfunction	Please contact the designated after-sales service station for repair or replacement.
The plug of battery level indicator is loose or disconnected	Please contact the designated after-sales service station for repair or replacement.	
The battery level indicator malfunction	Please contact the designated after-sales service station for repair or replacement.	

ITEM	FAULT CAUSE	TROUBLESHOOTING METHODS
<b>Charger not working</b>	The battery in temperature protection	Wait for the battery temperature to return to normal
	The connector of charger is loose or disconnected	Plug off and plug in the charger
	Charger malfunction	Replace the charger
	Battery malfunction	Please contact the designated after-sales service station for repair or replacement.
	The battery over discharge need to be Reactivate	Activate the battery
<b>USB doesn't work</b>	The connector of USB is loose or disconnected	Reconnected the USB
	The converter of USB is damaged	Replace the USB converter
<b>Riding mode function doesn't work or the power of the vehicle decreased</b>	Low battery protection	Charge the battery
	The battery is in temperature protection	Wait for the battery temperature to return to normal
	The motor is in temperature protection	Wait for the motor temperature to return to normal
	Riding mode switch is damaged	replace the riding mode switch
<b>Insufficient range for one charge</b>	Low tires pressure	Inflate the tires to the appropriate air pressure
	The charger is malfunctioned	Check the connector of charger is loose or disconnected
	Improper brake pads adjustment	Reset the brake pads
	The battery is overuse or damaged	Replace battery
	More uphill, frequent acceleration and deceleration,	It is normal
<b>Abnormal sound when riding</b>	The tightness of the chain is inappropriate	Adjust the tightness of the secondary chain
	Belt tightness is inappropriate	Adjust the tightness of the Primary belt
	The braking system is not properly installed	Dust in brake disc and brake pads,need to be cleaned;or the brake calipers are loose or improperly installed
<b>Other Fault</b>	When you encounter a fault that cannot be solved or identified by	In case of the above situation, please contact the local authorized dealer, do not disassemble the above parts without authorization, otherwise it might void your warranty
	The motor, controller, charger, and battery are damaged	

## MAINTENANCE GUIDANCE

In principle, the first inspection (also known as the first maintenance) can be done at 10-30km if ride normally.

### Check parts



#### WARNING

During the whole maintenance process, the bike cannot be powered on, which means you cannot do maintenance with the bike is powered on.



#### Note

- The front and rear brakes are disc brakes. When the brake pads are worn severely, please replace them as soon as possible.
- Keep the disc brake system clean in daily basis use and avoid long-term adhesion of sediment, especially oil pollution.

1. The tightness of the spokes on the front and rear wheels.
2. If there is a gap in the headset.
3. Check the tightness of chain.
4. Belt tightness inspection. (There may be some friction on the new belt, which can be waxed on both sides of the belt)
5. Suspension adjustment. Check if there is oil leakage, and if the compression and rebound damping is in the correct position. (During adjustment, do not turn the adjusting knob to the extreme position)
6. Check the tightness of all screws on the handlebars.

Extra attention should be paid to your safety during the inspection.

- Choose a wide, flat area to park your bike.
- When inspection is needed, it should be carried out in a safe place and pay close attention to the surrounding environment.
- If there is any abnormality during the inspection, please rectify the abnormality before riding. If the problem is difficult for you to solve, please contact Rerode or the local authorized dealer.

### Check Operational Unit



#### Note

- The belt tension has been adjusted before delivery. Please do not adjust it without permission.
- Hold the brake lever tightly. If the braking performance is still not good, check the cleanness of the discs. If the problem cannot be solved, please contact your local authorized dealer for inspection.

1. Check if the suspension is bent, deformed, or damaged:

Check if the front fork is damaged, loose or oil leakage and other faults. Shake the handle- bars up and down to check whether there is any abnormal sound caused by the front fork fault. If the front fork is malfunctioned, please contact Rerode or the local authorized dealer

2. Check Brakes:

Check if the free space of the brake lever is within the specified range (15-30mm). Adjust If it does not meet the requirements after measurement.

3. Check if the brakes function well:

Please ride at low speed on dry flat road for inspection, and use the front and rear brakes respectively to check their braking effective.

4. Check Tires:

The tires will be damaged by glass, stones and other matter on the ground. Please pay attention to the road condition when riding. Avoid riding in places where tires may be easily damaged. In addition, you should often check if the tires have distinct cracks and other damages.

- 1 ) Check the tire pressure with the tire pressure gauge when in the cooling condition.
- 2 ) Check if there are cracks, damages or abnormal wear.
- 3 ) Check if the spokes of the wheel are loose.
- 4 ) Check the tightness of the chain. Up and down 10-20mm.

5. Check the depth of tire grooves:

Check tire wear, groove depth. If wear reached 2/3 of the convex block, the tire should be replaced. When there is abnormal sound or swing in the tire, please contact your local authorized dealer for inspection and maintenance.

The pivot shaft nut locking torque should be 30 N·m, and the rear axle nut locking torque should be 40 N·m, The front axle screw locking torque depend on the front fork.

## Check the Battery

- Note**
- Before installing or removing the battery, please close the key switch and turn off the air circuit switch, and close the sealant cap of charging port.
  - If the battery cannot be put into the battery compartment, please take out the battery and check if the battery is stuck by other objects such as cable harness.
  - It is recommended that in winter the indoor temperature for battery storage should be above 0°C (32°F) and the battery remaining capacity should be checked regularly.

1. Check the Power:  
The bike is powered by a sealed lithium-ion battery. The battery should be fully charged before the inspection. Use a multimeter to test the positive and negative voltage of the discharge port, the normal full voltage should be between 83.6-84V.
2. Check Battery Appearance:  
Check if the battery's upper and lower sealing caps and the LCD screen are damaged. It will cause water get into the power pack if the sealing is damaged. Please Contact the local authorized dealer if the battery case or cap is damaged.

## Charging and Charger Usage

1. When charging, you are required to use the OEM charger. Do not use third-party charger, it might damage the battery and cause serious injury.
2. Check if the input voltage of the charger is same with the voltage of the power supply.
3. When the battery is fully charged, the charger will automatically stop charging. Avoid connecting the charger to the power supply for a long time.
4. Users are prohibited to disassemble the battery, disassemble battery without permission may cause serious injury.
5. When the battery is under over-discharge protection, it needs to be re-activated. Please refer to P25 "Troubleshooting" for activation method.

## Motor and Controller Usage and Maintenance

**WARNING** Warning: Do not exceed the wheel center when driving through water. Prolonged exposure of the motor to water may result in motor failure.

**Note**  
When the temperature of the motor and the controller is too high or the battery capacity is too low, the bike will automatically reduce the power to protect the power train.

1. Check tightness of the motor screws regularly.
2. Check the motor and controller insulation condition regularly.
3. Check the fuse condition regularly.
4. Do not wade in deep water, it might affect the motor operation.

## Replace Fuse

- Note**
1. The fuse should be firmly fixed on the fuse stand. If the fuse connecting part is loose, it may cause the fuse to heat up rapidly and then cause other faults and dangers.
  2. Replace the fuse with the correct specification. If the fuse doesn't match the requirement, it may fail to protect the system.
  3. If the fuse is melted again after replacement, you should check all the related cables to see if there are still other short circuits.
  4. Avoiding high press washer direct use on the fuse.

If the speedometer, horn, and headlight do not work after the air circuit switch and key switch are turned ON, the fuse may be melted. If the fuse needs to be replaced, please turn off the air circuit switch first. The operation method is as follows:  
Open the battery compartment cap, turn off the air circuit switch, take out the battery, the fuse box can be seen in front of the air circuit switch, and open the fuse box. (the fuse box is wrapped with black insulation tape)

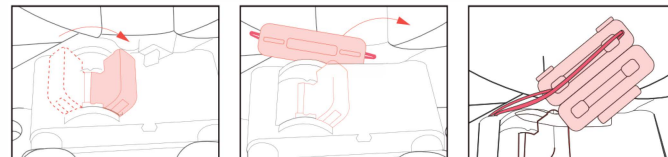

Turn off the Air Circuit Switch

Find the fuse box

Replace it with auxiliary fuse

## CONDITION OF WARRANTY

Rerode hereby warrants the new R1 motorcycle purchased from an authorized Rerode dealer to be free from defect in materials and workmanship for the period of time stated herein, subject to certain limitations stated herein. This warranty applies only if the bike has been properly set-up and serviced for pre-delivery by an authorized Rerode dealer. The warranty applies only if the motorcycle has been operated and maintained in accordance with the owner's manual or other Rerode literature delivered with the bike. This warranty is void if the ONLINE OWNER'S REGISTRATION/ DEALER PRE-DELIVERY INSPECTION has not been completed in full and entered into Rerode Distributor website within 7 days of purchase by the original selling dealer.

## PACKING LIST

Please carefully check whether all items in the package are complete and intact or not, If there are any problems such as damages or missing , you can contact the dealer or the manufacturer for assistance.



THE ACTUAL APPEARANCE AND FUNCTIONALITY OF THE PRODUCT MAY DEVIATE FROM THE INFORMATION PROVIDED IN THE USER MANUAL DUE TO TECHNOLOGICAL UPGRADES AND FIRMWARE UPDATES. PLEASE RELY ON THE PHYSICAL PRODUCT FOR ACCURATE DETAILS.FOR THE LATEST FEATURE DESCRIPTIONS AND SAFETY USAGE GUIDELINES, PLEASE VISIT OUR COMPANY'S OFFICIAL WEBSITE AND REFER TO THE ELECTRONIC USER MANUAL



User Manual & After-sales Manual



Packing List & Quick Assembly Guide



Display Manual

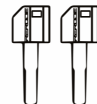

key\*2



Charger storage bag



Front Fender

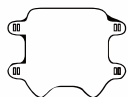

Number Plate



Toolkit



Foot Peg

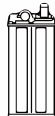

Battery

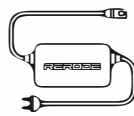

Charger



Rubber Zip Tie \*2



8\*200mm Zip Tie\*4